



Statens vegvesen

HCT – Status Norway 2023



Henriette Erken Busterud/
Statens vegvesen

74 tonne timber transport trial

- Status October 2023
 - 7 companies, 30 vehicle combinations, one new participant in 2023
 - Trial ends July 2025
- Recent activities
 - 3 year programme (2023 – 2025) measuring road degradation, to observe development over time
 - Load bearing capacity tests spring and autumn with falling weight deflectometer and Raptor (Rapid Pavement Tester)





Increased weights

	Total	EMS type 1 + 2 + 24 m combo (60t)	24m/60 t timber	Max 19.50 m/50 t
National roads	11 247 km	9 963 km (88 %)	10 119 km (90%)	650 km
County roads	45 166 km	7 577 km (17%)	26 961 km (60%)	8 029 km
Municipality roads	39 812 km	2 096 km (5%)	7 448 km (19%)	7 704 km
Total	96 226 km	19 636 km	44 483 km	18 022 km

- Continued process to permit more roads for EMS type 1 and 2
- Weights above 50 tonnes tied to max permitted length 24 m
- Possible to permit increased weights without increasing permitted length to 24 m?
 - Particularly county and municipality roads



Increased weights

- Requests by the transport industry
- Report by published in September calculating the social benefits of permitting increased weights for a selection of vehicles and vehicle combinations (Transportøkonomisk Institutt TØI 1950/2023)
- NPRA is currently in the process of deciding on how to proceed with the results
 - Which vehicles / vehicle combinations?
 - Which roads / form of implementation?
 - Portion of increase reserved for zero-emission vehicles?

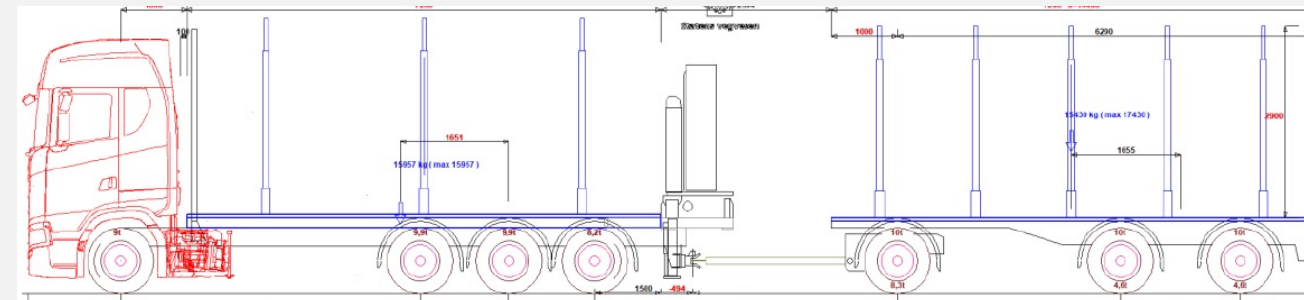
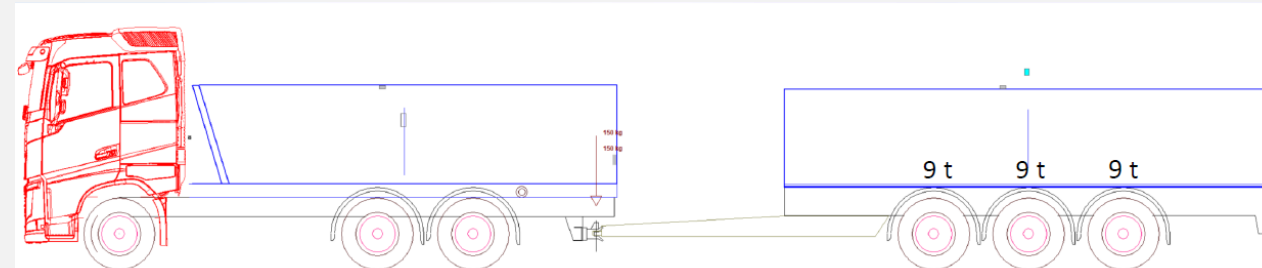
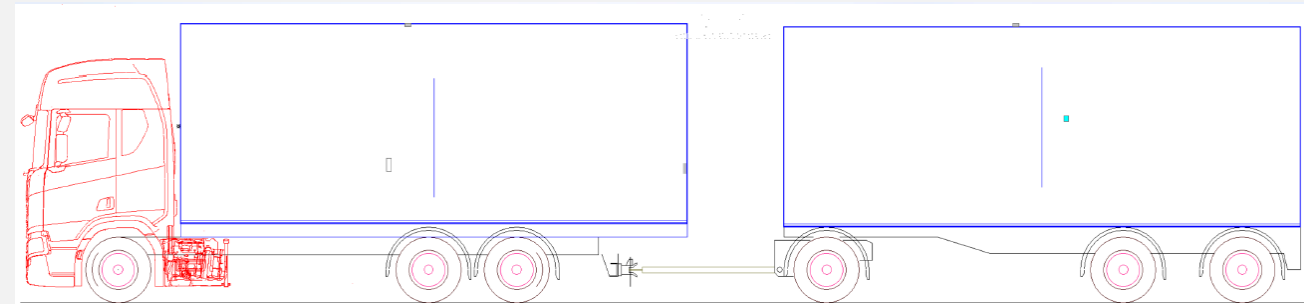
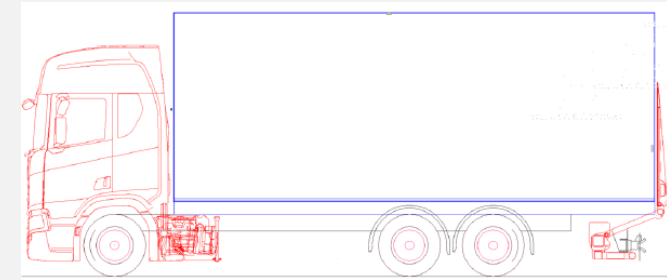

Digitalisation of road lists

Currently

- 6 types of road lists, separate publications for each 11 counties and national roads, 72 lists in total
- 2x per year, ca. November and May

Vegportalen («The Road Portal») launched in June 2023

- New digital system for road authorities to report changes to road lists through map interface
- First batch of road lists from the new system in November 2023
- Down from 72 to 6 lists
- Monthly updates starting in 2024

Vegliste 2022

TØMMERTRANSPORT

Fylkes- og kommunale vegger

November 2022

Agder

www.vegvesen.no/vegllister



Veg	Vegstrekning	Veglengde (km)	Bk/totalvekt (tonn)	Bk/totalvekt vinter (tonn)	Tillatt vogntoglengde (m)	Tillatt for modulvogntog 1 og 2 med sporingskrav
Fv. 2188	Åmot/Stor-Elvdal—Neta bru	13,500	Bk10/60		24,00	Nei
Fv. 2188	Neta bru—Evenstad x jernbanen	8,760	Bk10/60		24,00	Ja
Fv. 2188	Arm Evenstad—Evenstad bru x rv. 3	0,679	Bk10/60		24,00	Ja
Fv. 2188	Evenstad x jernbanen—Kjemåa x fv. 30	17,529	BkT8/50	Bk10/60	24,00	Nei
Fv. 2188	Stai bru Ø x fv. 2188—Stai bru x rv. 3	0,255	Bk6/28		24,00	Nei
Fv. 2198	Opphus V x rv. 3—Opphus bru Ø	0,204	Spesiell begrensning		24,00	Nei
Fv. 2198	Opphus bru Ø—Opphus øst x fv. 2188	0,389	BkT8/50	Bk10/50	24,00	Nei
Fv. 2200	Nysted x fv. 30—x kv.	0,528	Bk10/60		24,00	Ja



Vegportalen

Vegliste Innsendte saker Hjelp Neste publisering: 1. november 2023 kl. 12:00 KDDNITV/PARYKK Logg ut

Tilbake til vegliste

Normal Spesial Tommer Modulvogntog 12/05 mobilkran 12/100 vegnett

Splitt strekning Rediger strekning

FV22 S1D1 m0 - S1D1 m222

Gjelleråsen x rv. 4 - Hvam x E6

Egenskaper

Bruksklasse
BK10 - 50 tonn

Bruksklasse vinter
-

Maks vogntoglengde
19,50

undefined

undefined

Strekning

Veglengde (m)
222.373

Fra	
SxDx	Meter
S1D1	0
Til	
SxDx	Meter
S1D1	222.374

Merknad
-

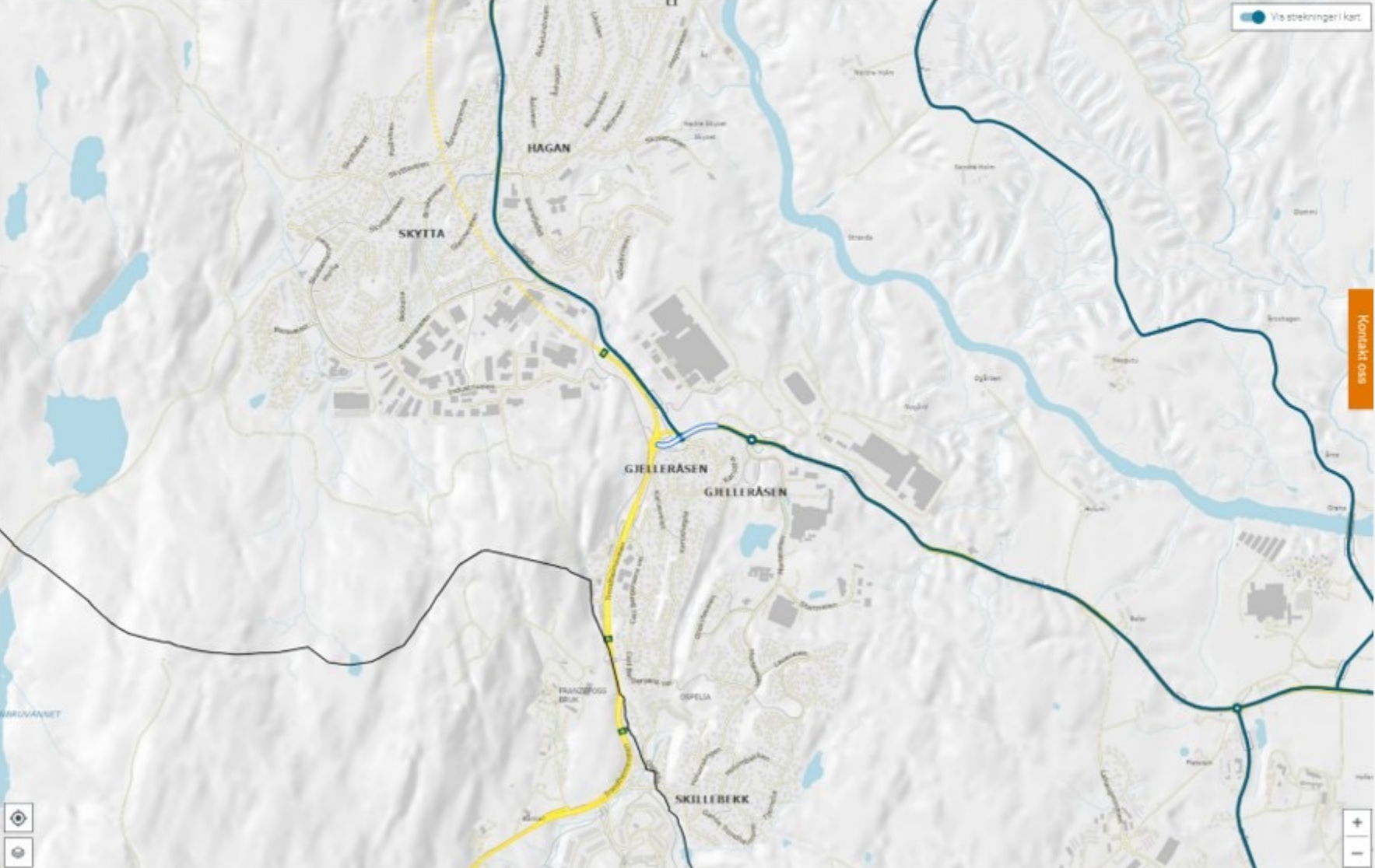

Vis strekninger i kart

Kontakt oss

Map navigation controls



Statens vegvesen

elin.norby@vegvesen.no

